

More Reliability for Railway Low Voltage Power Requirements

Many manufacturers of power conversion equipment for rail or transit depend on standard commercial components. This white paper explores the increasingly strong demand for more rugged and therefore more reliable power conversion products to meet the demands of the rail/transit industry by reducing their downtime for maintenance to a minimum. It also studies the challenges posed by Analytic Systems' initial customer as to how they improved their error reporting capability for their power units.

Illinois Commuter Rail Operator Metra was experiencing unacceptable downtime related to their low voltage power supply used to power all low voltage electrical on board: lights, etc. A 480V 3 phase input UPS combining both an AC to DC power supply and a separate battery charger that provides regulated 32VDC power to the low voltage power systems. In case of a failure of the 480VAC feed, the low voltage systems are maintained from the batteries.

In addition to inadequate reliability, Metra's previous product lacked field serviceability and adequate monitoring/data collection capability. Their supplier preferred having the units sent back to their factory (in France) without sending a representative to Metra to explore options and develop innovative solutions. When Analytic Systems was offered the opportunity, they went to Metra's facility in Chicago to review the situation and gain a better understanding of the projects' requirements. They had not built a 480vdc, 3ph unit before, but were confident that it was well within their scope of operation and high on their list of new product evolution. This project gave them an opportunity to grow in a relatively new market. They had the knowhow and the engineering resources available just at the right time.

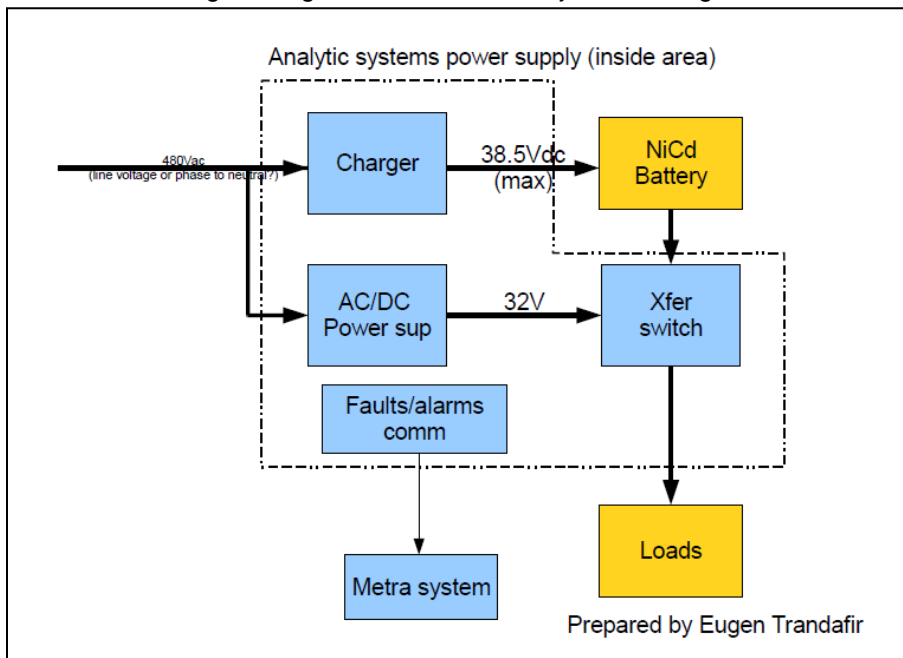

Key Metra criteria were lower cost of ownership and greater power system reliability. A key design limitation was that the recommended charging algorithm to maximize the performance of Metra's NiCad batteries required that the battery/battery charger circuit be isolated from the load. A DC Power supply feeds a regulated 32VDC to the loads. A separate Battery charger provides 38.5VDC to the battery string. Con't...2

...2

As there is no direct connection between the battery and the loads in normal operation the charger can make use of power saving /charging technologies. In the event of a failure of either the 480VAC power feed or the AC/DC power supply the transfer switch will trigger DC power to the loads from the battery.

Modular construction was used as a design basis to be easier to build (reduced cost) and easier to repair (lower down time) with back up inventory to be shipped on 24 hour notice if needed. The Charger and AC/DC Power supply modules are identical in design and construction with their functionality determined by the on board microprocessor. Analytic Systems' BCA-PWS480-36 was designed as a custom dedicated unit to meet Metra's strict specifications.

The modular construction combined with microprocessor control will allow Analytic Systems to use the basic design for future custom opportunities and the freedom to do more than just charge the current battery. Should Metra, or another user, wish to make a change to a new battery chemistry/technology in the future the unit's computer control enables it to be firmware modified to charge many different battery chemistries and be applicable to other high voltage applications: military, industrial, etc.

Here are a few features of the Analytic Systems' BCA-PWS480-36 low voltage power system:

- -40C to +70°C operating temperature. The most rugged components were specified to provide the greatest reliability in a wide temperature, high vibration under rail environment. All life time limited components such as electrolytic capacitors are long life (>70,000hrs at 105C with ripple) and wide temperature storage range (-40C to +105C). High voltage semiconductors are derated in applied voltage to minimize failure due to the 'Single Event Burnout' (SEB) effect."
- Event data logging with SD card data storage allowing data recovery even in cases of catastrophic module failure. LED display allows system diagnostics without a laptop computer or other interface device.
- Convection cooled. The unit was designed with superior, proprietary thermal transfer management systems designed for superior reliability with the assistance of a local university that specializes in thermal management studies.
- The model is 93% efficient and has a 0.9-0.95 power factor (passive solution).
- It starts up and operates on its own without a separate auxiliary supply with default safe values for its output voltage setting. This allows basic function (powering the load from AC line) even with the digital PCB failed. A bypass diode on the power supply output allows powering of the load with the contactor failed or not closed due to digital PCB or software failure. If one of the converters fails then the contactors can be operated such that the other can power the load and maintain some level of charge in the batteries. The converters also would run on single phase at half power if allowed by the digital PCB software.

Con't...3

...3

Analytic Systems design and product development capabilities allowed them to deliver a product in the form of the BCA-PWS480-36 Power System which addressed all the concerns that Metra had with its incumbent system at a significant savings in purchase, operating and maintenance costs while providing a number of firsts for Analytic Systems:

- First 3ph, 480V power supply
- First field upgradeable firmware (customer will not need to ship the 70+ lb unit back if they wanted additional features or bug fixes) this allows the upgrades to be sent over the internet
- First SD card logging system;
- Error reporting will allow the user to diagnose the unit without a need for a laptop or other special hardware (saving costs)
- LED display powered by automatic software control (shows all error codes)
- Communication protocols for monitoring and data logging of operating parameters
- First forward converter active clamp with 4 mosfets in series.

For further information please contact;
Bill Walker
Vice President, Sales and Marketing
Analytic Systems
ISO9001 Certified

North American TF #800-668-3884
billw@analyticsystems.com